



# IC Recorder

## Operating Instructions

### Owner's Record

The model number is located at the rear and the serial number is located inside the battery compartment. Record the serial number in the space provided below. Refer to these numbers whenever you call upon your Sony dealer regarding this product.

Model No. ICD-B100/B200 Serial No. \_\_\_\_\_

# IC RECORDER

## ICD-B100/B200

©2004 Sony Corporation Printed in China

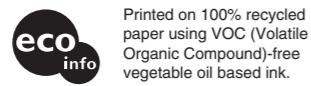

Printed on 100% recycled paper using VOC (Volatile Organic Compound)-free vegetable oil based ink.

http://www.sony.net/

### Information

IN NO EVENT SHALL SELLER BE LIABLE FOR ANY DIRECT, INCIDENTAL OR CONSEQUENTIAL DAMAGES OF ANY NATURE, OR LOSSES OR EXPENSES RESULTING FROM ANY DEFECTIVE PRODUCT OR THE USE OF ANY PRODUCT.

### For the customers in the U.S.A.

#### INFORMATION

This equipment has been tested and found to comply with the limits for a Class B digital device, pursuant to Part 15 of the FCC Rules. These limits are designed to provide reasonable protection against harmful interference in a residential installation. This equipment generates, uses, and can radiate radio frequency energy and, if not installed and used in accordance with the instructions, may cause harmful interference to radio communications.

However, there is no guarantee that interference will not occur in a particular installation. If this equipment does cause harmful interference to radio or television reception, which can be determined by turning the equipment off and on, the user is encouraged to try to correct the interference by one or more of the following measures:

- Reorient or relocate the receiving antenna.
- Increase the separation between the equipment and receiver.
- Connect the equipment into an outlet on a circuit different from that to which the receiver is connected.
- Consult the dealer or an experienced radio/TV technician for help.

You are cautioned that any changes or modifications not expressly approved in this manual could void your authority to operate this equipment.

This device complies with Part 15 of the FCC Rules. Operation is subject to the following two conditions: (1) This device may not cause harmful interference, and (2) this device must accept any interference received, including interference that may cause undesired operation.

If you have any questions about this product, you may call: Sony Customer Information Services Center 1-800-222-7669 or http://www.sony.com/

### Precautions

#### On power

- Operate the unit only on 3 V DC. Use two LR03 (size AAA) alkaline batteries.

#### On safety

- Do not operate the unit while driving, cycling or operating any motorized vehicle.

#### On handling

- Do not leave the unit in a location near heat sources, or in a place subject to direct sunlight, excessive dust or mechanical shock.
- Should any solid object or liquid fall into the unit, remove the batteries and have the unit checked by qualified personnel before operating it any further.

#### On noise

- Noise may be heard when the unit is placed near an AC power source, a fluorescent lamp or a mobile phone during recording or playback.
- Noise may be recorded when an object, such as your finger, etc., rubs or scratches the unit during recording.

#### On maintenance

- To clean the exterior, use a soft cloth slightly moistened in water. Do not use alcohol, benzine or thinner.

If you have any questions or problems concerning your unit, please consult your nearest Sony dealer.

#### Backup recommendations

To avoid potential risk of data loss caused by accidental operation or malfunction of the IC recorder, we recommend that you save a backup copy of your recorded messages on a tape recorder, etc.

### ▶Getting started

## Step 1: Installing the Batteries

### 1 Slide and lift the battery compartment lid.

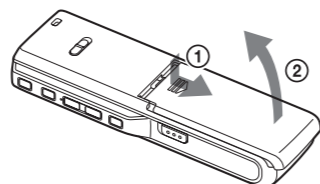

### 2 Insert two LR03 (size AAA) alkaline batteries with correct polarity, and close the lid.

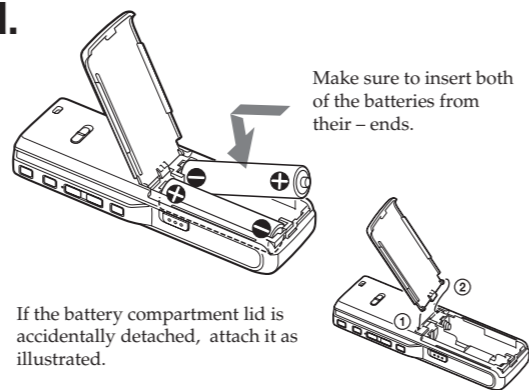

Make sure to insert both of the batteries from their - ends.

If the battery compartment lid is accidentally detached, attach it as illustrated.

Click setting display appears when you insert batteries for the first time, or when you insert battery after the unit has been without batteries for a certain period of time. Please refer to Steps 2 to 3 in "Step 2: Setting the Clock" to set the date and time.

## Step 2: Setting the Clock

Click setting display appears when you insert batteries for the first time, or when you insert battery after the unit has been without battery for a certain period of time. In this case, proceed from step 2.

### 1 Display the clock setting display.

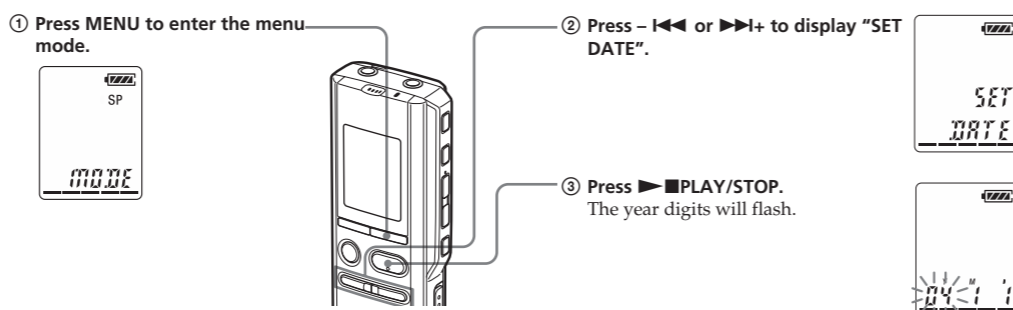

### 2 Set the date.

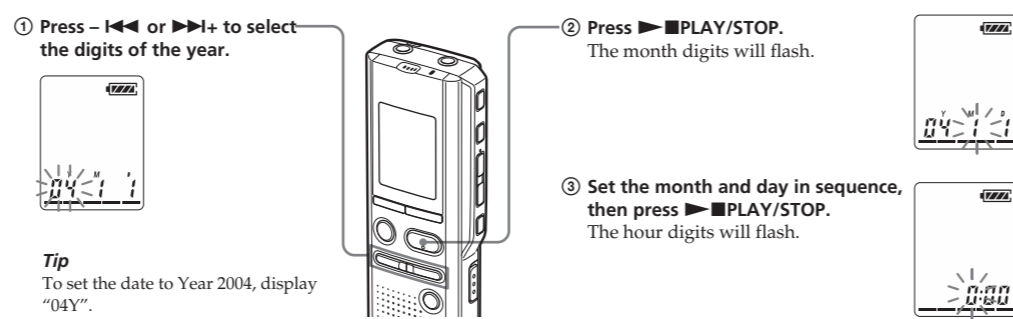

### 3 Set the time.

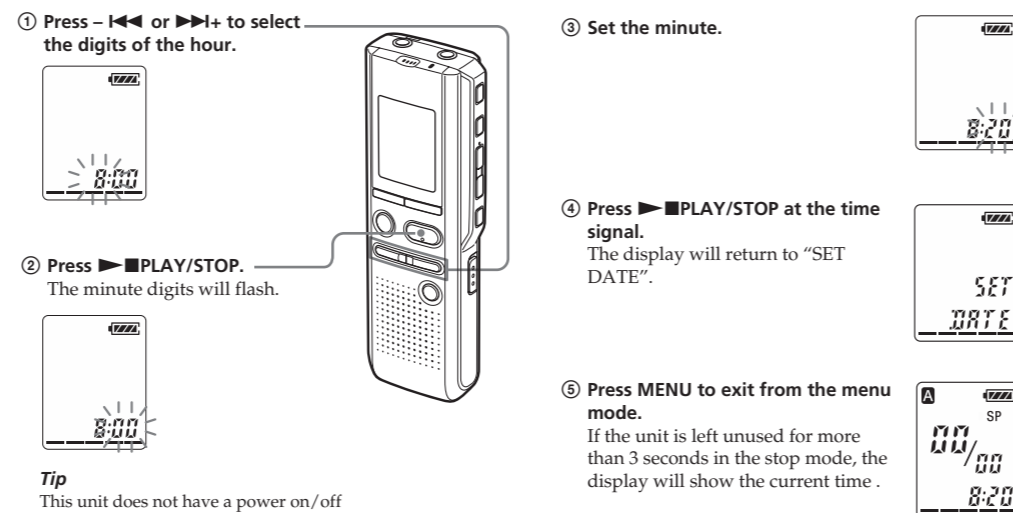

**Tip**  
This unit does not have a power on/off switch. The display is shown at all times.

#### Replacing the batteries

The battery indicator on the display window shows the battery condition. When [ ] flashes, replace the batteries with new ones. When [ ] flashes, the batteries are exhausted and the unit will stop operation.

#### Battery life\*

With continuous use, approx. 7.5 hours recording/5 hours playback in the HQ mode, and approx.15.5 hours recording/8.5 hours playback in the SP and LP modes is possible.  
\* Using Sony alkaline batteries LR03 (size AAA)  
\* When playing back through the internal speaker with the medium volume level  
The battery life may shorten depending on the operation of the unit.

#### Notes

- Do not use manganese batteries for this unit.
- When you replace the batteries, insert the new ones within 3 minutes after you removed the exhausted ones. Otherwise, the display may show the clock setting display or incorrect date and time when you reinsert the batteries. In this case, set the date and time again. The recorded messages and alarm signal, will remain.
- When replacing the batteries, be sure to replace both batteries with new ones.
- Do not charge dry batteries.
- When you are not going to use the unit for a long time, remove the batteries to prevent damage from battery leakage and corrosion.
- The unit is accessing data while "ACCESS" appears in the display window. While accessing, do not remove the batteries. Doing so may damage the data.

### ▶Basic Operations

## Recording Messages

You can record up to 99 messages in each of the four folders (A, B, C, and D). Since a newly recorded message is automatically added behind the last recorded message, you can start recording quickly without searching for the end of the last recording.

e.g.	Message 1	Message 2	Newly recorded message	Blank space
------	-----------	-----------	------------------------	-------------

#### Note

Before making a long recording, be sure to insert new batteries and check the battery indicator.

### 1 Select the recording mode.

For how to select the recording mode, see "Changing the Recording Mode" on the reverse side.

### 2 Select the folder.

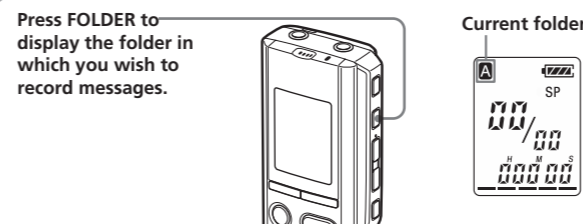

### 3 Start recording.

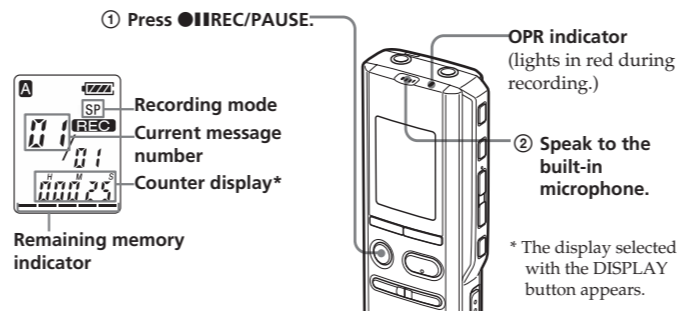

You do not need to keep pressing I/REC/PAUSE while recording.

### 4 Stop recording.

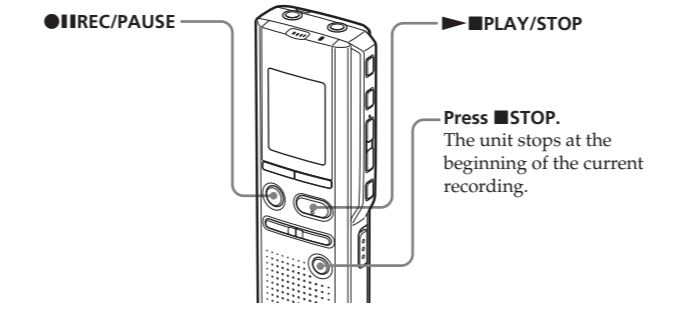

If you do not change the folder after you stop recording, the next time you record you will record in the same folder.

To	Do this
pause recording*	Press I/REC/PAUSE. During recording pause, the OPR indicator flashes in red and "PAUSE" flashes in the display window.
release pause and resume recording	Press I/REC/PAUSE. Recording resumes from that point. (To stop recording after pausing recording, press I/STOP.)
listen to the current recording	Press I/STOP to stop recording, then press I/PLAY/STOP.
review the current recording instantly	Press I/PLAY/STOP during recording.
select the microphone sensitivity	You can select the microphone sensitivity by setting MIC SENS. HIGH: To record at meeting or in a quiet and/or spacious place. LOW: To record for dictation or in a noisy place.

\* About one hour after you pause recording, recording pause is automatically released and the unit goes into the stop mode.

#### Note on recording

Noise may be recorded if an object, such as your finger, etc., accidentally rubs or scratches the unit during recording.

#### Maximum recording time

The maximum recording time of all the folders is as follows. You can record messages for the maximum recording time in a single folder.

	ICD-B100	ICD-B200
HQ*	1 h. 45 min.	3 h. 40 min.
SP**	4 h. 50 min.	9 h. 50 min.
LP***	8 h.	16 h. 10 min.

(h.: hours/min.: minutes)  
\* HQ: High quality recording mode (monaural sound)  
\*\* SP: Standard play recording mode (monaural sound)  
\*\*\* LP: Long play recording mode (monaural sound)

#### Notes

- To record in better sound quality, select the HQ mode. For switching the recording mode, see "Changing the Recording Mode" on the reverse side.
- Before making a long recording, be sure to check the battery indicator.
- The maximum recording time and the number of messages you can make varies depending on the conditions of use.
- When you record messages in the mixture of HQ, SP and LP mode, the maximum recording time will be between those for the HQ and LP modes.
- Due to the limitation of the IC recording system, this unit records in the minimum recording unit of approx. 30 seconds at most, therefore the following symptoms may occur:
  - When a message is shorter than the minimum recording unit, it is still counted as approx. 30 seconds at most so the remaining recording time will decrease by more than the actual length of the message.
  - When the message is longer than the minimum recording unit, the remaining recording time will decrease by more than the actual length of the message if it cannot be divided by the minimum recording unit without a remainder.
  - The sum of the number on the counter (elapsed recording time) and the remaining recording time may be less than the unit's maximum recording time.

#### Remaining memory indication

During recording, the remaining memory indicator decreases one by one.

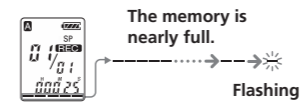

When the remaining time of recording reaches 5 minutes, the last one of the indication flashes. If the remaining recording time display mode is selected, "REMAIN" will also flash when the remaining time reaches 1 minute. When the memory is full, recording automatically stops and "FULL" will flash in the display window with an alarm sound. To continue recording, first erase some of the messages.

#### Notes

- If you press I/REC/PAUSE when the memory is full, "FULL" will flash with an alarm sound. Erase some of the messages before you start recording again.
- If you press I/REC/PAUSE after you have recorded 99 messages, "FULL" will flash with an alarm sound. Select another folder or erase some of the messages.

#### Starting recording automatically in response to the sound — Advanced VOR function

When VOR (voice operated recording) is set to ON in the menu, recording starts when the recorder detects sound. ("VOR" is displayed in the display window.)

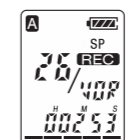

Recording stops when no sound is heard. ("VOR PAUSE" flashes in the display window.)

#### Note

VOR function is affected by the sound around you. Set the MIC SENS to HIGH or LOW. If recording is not satisfactory after you have changed the microphone sensitivity, or for important recording, set VOR to OFF.

## Playing Back Messages

When playing back a previously recorded message, start from Step 1. When playing back a message you have just finished recording, start from Step 3.

### 1 Select the folder.

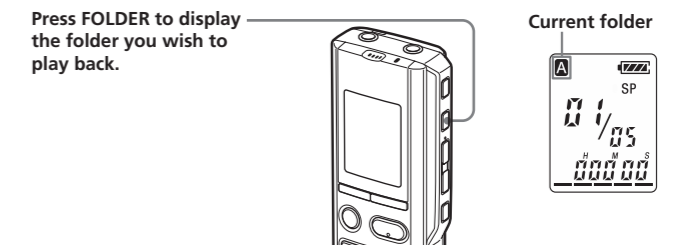

### 2 Select the message number.

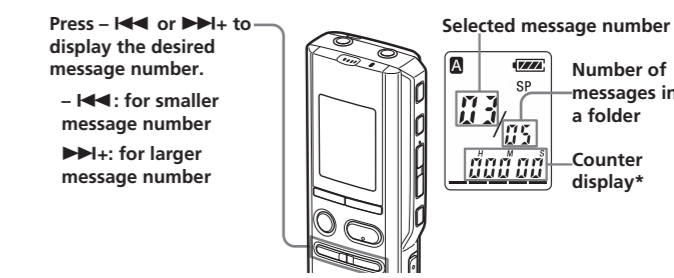

\* The display selected with the DISPLAY button appears (see the reverse side).

### 3 Start playback.

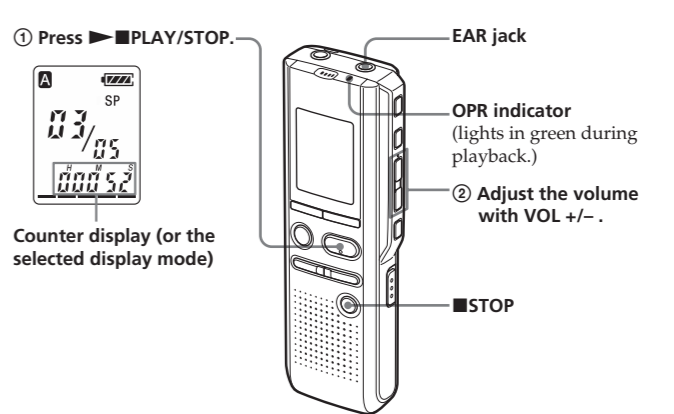

After playing back one message, the unit stops at the beginning of the next message. When the continuous play function is set to "ON" (see the reverse side), the unit stops after playing all messages in a folder. When the last message on a folder has been played back, the unit stops at the beginning of the last message.

If the last message is long and you wish to start playback at a later part of the message, keep I/PLAY/STOP to play back the message to the end and then press I/LEFT while "END" is flashing to go back to the desired point.

(For messages other than the last one, go to the beginning of the next message and play backward to the desired point.)

When fast playback is done to the end of the last message, "END" flashes 5 times. (You cannot hear the playback sound.) If you keep I/LEFT pressed while "END" is flashing, the messages are played back rapidly, and normal playback will start at the point you release the button.

When "END" stops flashing and the OPR indicator goes off, the unit will stop at the beginning of the last message.

When "END" stops flashing and the OPR indicator goes off, the unit will stop at the beginning of the last message.

When "END" stops flashing and the OPR indicator goes off, the unit will stop at the beginning of the last message.

When "END" stops flashing and the OPR indicator goes off, the unit will stop at the beginning of the last message.

When "END" stops flashing and the OPR indicator goes off, the unit will stop at the beginning of the last message.

When "END" stops flashing and the OPR indicator goes off, the unit will stop at the beginning of the last message.

When "END" stops flashing and the OPR indicator goes off, the unit will stop at the beginning of the last message.

When "END" stops flashing and the OPR indicator goes off, the unit will stop at the beginning of the last message.

When "END" stops flashing and the OPR indicator goes off, the unit will stop at the beginning of the last message.

When "END" stops flashing and the OPR indicator goes off, the unit will stop at the beginning of the last message.

When "END" stops flashing and the OPR indicator goes off, the unit will stop at the beginning of the last message.

When "END" stops flashing and the OPR indicator goes off, the unit will stop at the beginning of the last message.

When "END" stops flashing and the OPR indicator goes off, the unit will stop at the beginning of the last message.

#### Playing back a message repeatedly

— Repeat Play  
During playback, press I/PLAY/STOP for more than one second. "C" will be displayed and the selected message will be played back repeatedly.  
To resume normal playback, press I/PLAY/STOP again. To stop playback, press I/STOP.

#### Playing back all messages in a folder continuously

— Continuous Play  
You can select the continuous play mode with the CONT in the menu. When you set CONT to ON, you can play back all messages in a folder continuously.

#### Searching forward/backward during playback (Cue/Review)

To search forward, keep I/PLAY/STOP pressed during playback and release the button at the point you wish to resume playback.  
To search backward, keep I/LEFT pressed during playback and release the button at the point you wish to resume playback.

If you keep I/RIGHT or I/LEFT pressed, the unit starts to search at higher speed.

For the first 10 seconds of cue/review, fast playback sound can be heard. When searching at a higher speed, playback sound will not be heard.

During cue/review, the counter will be displayed, regardless of the display mode setting.

#### Tip

When fast playback is done to the end of the last message, "END" flashes 5 times. (You cannot hear the playback sound.) If you keep I/LEFT pressed while "END" is flashing, the messages are played back rapidly, and normal playback will start at the point you release the button.

When "END" stops flashing and the OPR indicator goes off, the unit will stop at the beginning of the last message.

When "END" stops flashing and the OPR indicator goes off, the unit will stop at the beginning of the last message.

When "END" stops flashing and the OPR indicator goes off, the unit will stop at the beginning of the last message.

#### Other operations

To	Do this
stop at the current position	Press I/PLAY/STOP or I/STOP. To resume playback from that point, press I/PLAY/STOP again.
go back to the beginning of the current message	Press I/LEFT once.
skip to the next message	Press I/RIGHT once.
go back to previous messages/skip to succeeding messages	Press I/LEFT or I/RIGHT repeatedly. (During stop mode, keep the button pressed to skip the messages continuously.)

# Erasing Messages

You can erase the recorded messages one by one or all messages in a folder at a time. Note that once a recording has been erased, you cannot retrieve it.

## Erasing messages one by one

When a message is erased, the remaining messages will advance and renumbered so that there will be no space between messages.

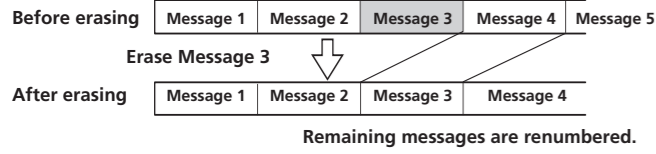

1 Press **ERASE** while playing back the message you want to erase or press **ERASE** for more than 1 second during stop mode. A beep will sound and the message number and "ERASE" will flash while the first and last 5 seconds of the message is played back 10 times.

2 Press **ERASE** while the message is being played back. The message is erased and the remaining messages will be renumbered. (For example, if you erase Message 3, Message 4 will be renumbered as Message 3. When erasing is completed, the unit will stop at the beginning of the following message.)

## Erasing all messages in a folder

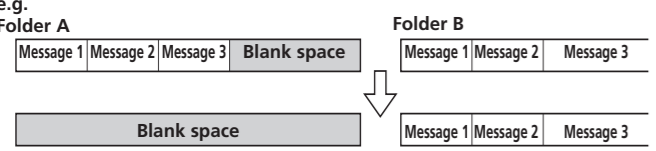

1 Press **FOLDER** to select the folder you want to erase.

2 While pressing **STOP**, press **ERASE** for more than 1 second. "ALL ERASE" will flash for 10 seconds.

3 While the display is flashing, press **ERASE**.

**To cancel erasing**  
Press **STOP** before step 2.

**To erase other messages**  
Repeat steps 1 and 2.

**To erase a message partially**  
First divide the message and then follow the steps to erase the message.

**To cancel erasing**  
Press **STOP** before step 3.

# Index to Parts and Controls

## Main unit

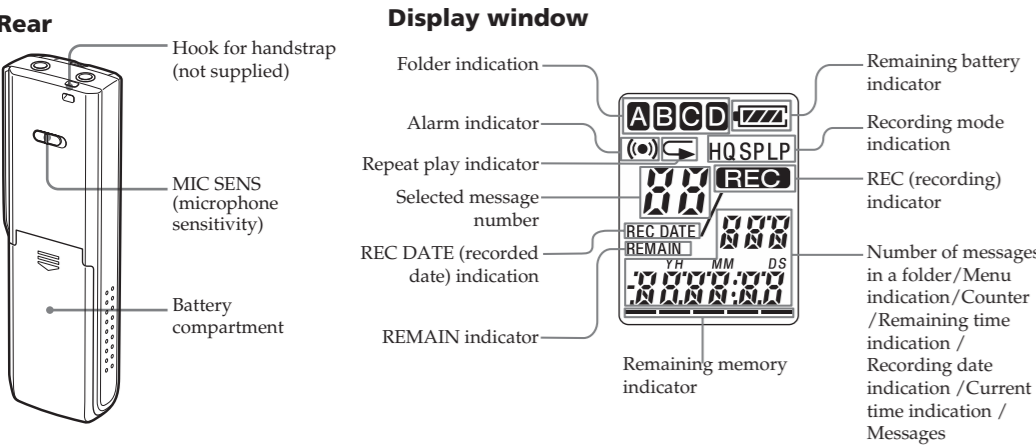
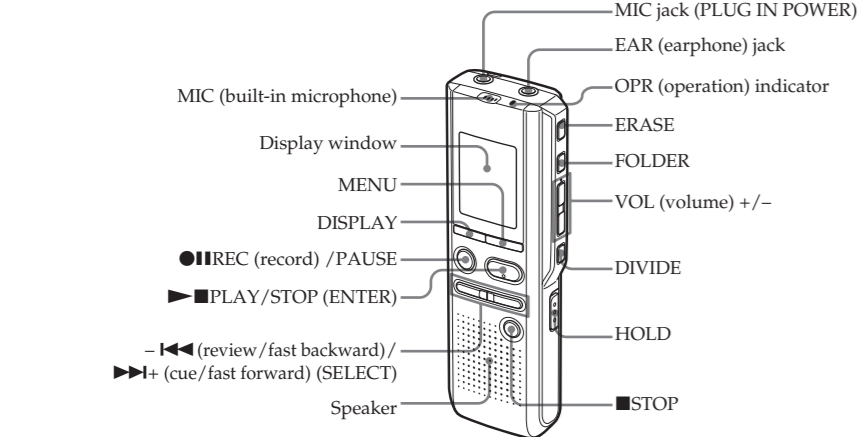

## Various Ways of Recording

### Adding a Recording to a Previously Recorded Message

You can add a recording to the message being played back. The added recording will be placed after the current message and counted as a part of the message.

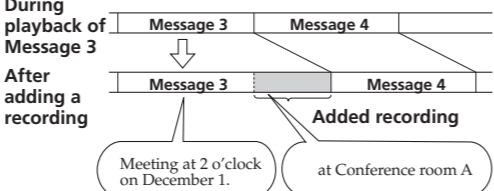

1 During playback, press **REC/PAUSE** for more than 1 second. The "REC" indication appears and "ADD" will flash three times on the display window. The OPR indicator will turn red. The new recording will be added at the end of the current message.

2 Press **STOP** to stop the recording.

**Notes**

- You cannot add a recording if the remaining memory is not long enough.
- The added portion of a message will be recorded in the same recording mode (HQ, SP, or LP).

### Recording with an External Microphone or from Other Equipment

1 Connect a plug-in-power type microphone or other equipment to the MIC (PLUG IN POWER) jack.

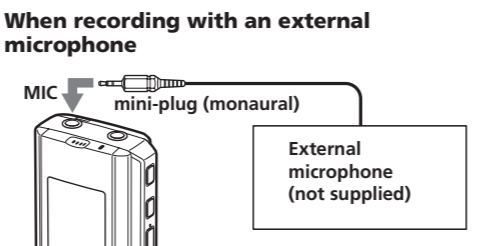

When you connect an external microphone, the built-in microphone is automatically cut off. When a plug-in power type microphone is connected, power is automatically supplied to the microphone from the IC recorder.

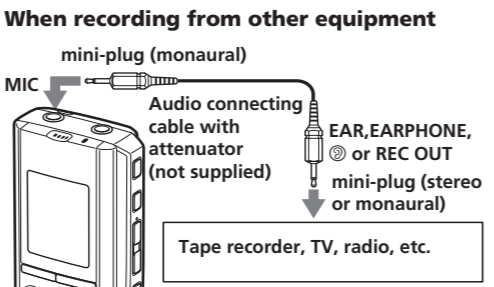

2 Follow the steps in "Recording messages" to record messages.

**Notes**

- Make sure that the plugs are connected securely.
- We recommend you make a trial recording to check the connections and volume control.
- When connecting equipment other than Sony's, refer to the instruction manual of the equipment.

### Starting recording automatically in response to the sound — Advanced VOR function

**VOR ON:** The VOR (Voice Operated Recording) function is activated. Recording starts when the unit detects sound and stops when no sound is heard, eliminating recording from soundless period.

**VOR OFF:** The VOR function is disabled. Normal recording operation is selected.

- Press **MENU** to enter the menu mode.
- Press **←** or **→** to display "VOR" and press **PLAY/STOP**. "OFF (or ON)" will flash.
- Press **←** or **→** to select "ON" or "OFF" and press **PLAY/STOP**. Now the setting is completed.
- Press **MENU** to exit the menu mode.

## Other Functions

### Dividing a Message

You can divide a message during recording or playback, so that the message is divided into two and the new message number is added to the divided message. By dividing a message, you can easily find the point you want to play back when you make a long recording such as a meeting.

You can divide messages until the total number of messages in the folder becomes 99.

**While recording or playing back a message, press DIVIDE at the point you want to divide.**

**When you press DIVIDE during recording:** The new message number is added at the point you pressed the button, and the new message number and "DIVIDE" flashes for 3 seconds. The message will be divided into two; however, the messages will be recorded without a break.

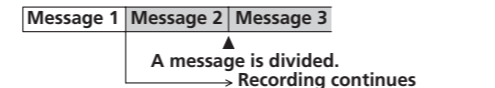

**Tip**  
You can divide a message during recording pause.

**When you press DIVIDE during playback:** The message is divided into two at the point you pressed the button, and the new message number and "DIVIDE" flashes for 3 seconds. The message numbers of the following messages will increase by one.

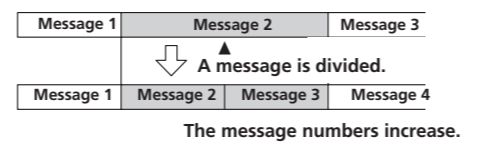

**To play the divided message**  
Press **←** or **→** to display the message number as the divided messages each have message numbers.

**Tip**  
To play the divided messages continuously  
Select ON for CONT in the menu as described in "Playing Back All Messages in a Folder Continuously".

**Notes**

- If 99 messages have been recorded in a folder, you cannot divide a message. In that case, reduce the number of messages to 98 or less by erasing unnecessary messages or by moving some of the messages to another folder before dividing a message.
- If you divide a message with an alarm setting, the alarm setting remains only with the former message divided.
- You cannot divide a message in the first or the last 1 second.
- If you divide a message frequently, the unit may become unable to divide a message.
- Once a message is divided, you cannot combine the divided messages with the IC recorder.

### Moving Messages to a Different Folder — Move Function

You can move the recorded messages to another folder. Example: Moving Message 3 in Folder A to Folder B

- Play back the message you want to move.
- While playing back the message, press **FOLDER** to flash the indication of the folder to which you want to move the message (B in this case). The first and last 5 seconds of the message will be played back 10 times, while the folder indication and "MOVE" flash.
- Press **PLAY/STOP**. The message is moved in the destination folder. Messages are sorted in order of the recorded date and time.

**To cancel moving the message(s)**  
Press **STOP** before step 3.

**Note**  
The move function does not duplicate a message in another folder. When you move a message to another folder, the one in the previous folder will be deleted.

### Playing Back a Message at a Desired Time with an Alarm

You can sound an alarm and start playback of a selected message at a desired time.

- Use **FOLDER** and **←** or **→** to select the folder and the message you want to play back.
- Enter the alarm setting mode.
  - Press **MENU**. The unit enters the menu mode and "ALARM OFF" will be displayed. (If "ALARM ON" is displayed, the alarm has been set. If you do not wish to change the setting, press **MENU** and exit the menu mode.)
  - Press **PLAY/STOP**. "OFF" starts to flash.
  - Press **←** or **→** to flash "ON".
  - Press **PLAY/STOP**. "DATE" will flash in the display window.

- Set the alarm date.
 

**To play back on a desired date**  
(the message will be played back at the same time on the same date every year until you erase the message)

  - Press **PLAY/STOP** while "DATE" is flashing. The month digits will flash.
  - Press **←** or **→** to select the month digits and press **PLAY/STOP**. The day digits will flash.
  - Press **←** or **→** to select the day digits.

**To play back once a week**  
Press **←** or **→** to select the day of the week.

**To play back at the same time every day**  
Press **←** or **→** to select "DAILY".

4 Press **PLAY/STOP**. The hour digits will flash.

5 Set the alarm time.
 

- Press **←** or **→** to select the hour digits and press **PLAY/STOP**. The minute digits will flash.
- Press **←** or **→** to select the minute digits and press **PLAY/STOP**. "ALARM ON" will be displayed.

6 Press **MENU** to exit the menu mode.

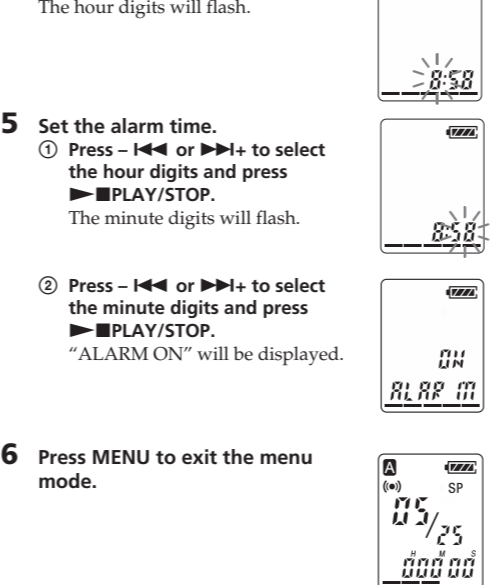

"\*" is displayed when the number of the message with alarm setting is selected. At the set time, the alarm will sound for about 10 seconds and the selected message will be played back. During playback, "ALARM" will flash in the display window. When the playback ends, the unit will stop automatically at the beginning of that message.

**To listen to the same message again**  
Press **PLAY/STOP**. The same message will be played back from the beginning.

**To cancel the alarm setting before the playback starts**  
Press **STOP** while the alarm sound is heard. You can stop even when the HOLD function is activated.

**Notes**

- You cannot set the alarm if you have not set the clock or there is no message in the selected folder (the unit will not enter the alarm setting mode when you press **MENU** in Step 2).
- If you try to set the alarm to play back a message at a previously set time on another message, "PRE SET" will be displayed, preventing new settings.
- If the alarm time comes while another message is being played back with an alarm, the playback stops and the new message will be played back.
- If the alarm time comes during recording, alarm will sound for 10 seconds after the recording is finished and playback begins. "M" will flash when the alarm time comes.
- If more than one alarm time comes during recording, only the first message will be played back.
- When the alarm time comes when the unit is in the menu mode, alarm will sound and the menu mode will be cancelled.
- If you erase the message you set the alarm to play back, the alarm setting will be cancelled.
- If you divide a message with the playback alarm, playback will stop at the point you divided a message.
- You can adjust the playback volume with VOL +/-.
- If the alarm time comes during erasing, alarm will sound for 10 seconds after the erasing is finished and alarm playback finishes. To cancel alarm setting, see below.

### To cancel the alarm setting or change the alarm time

- Select the message you set the alarm to play back, and press **MENU**. "ALARM ON" will be displayed.
- Press **PLAY/STOP** to flash "ON".
- To cancel the alarm setting: Press **←** or **→** to flash "OFF" and press **PLAY/STOP**. To change the alarm date and time: Press **PLAY/STOP**. When the alarm date is displayed, follow the steps 3 to 5 above to change the alarm date and time.
- Press **MENU** to exit the menu mode.

### Preventing Accidental Operation — HOLD function

Slide the HOLD switch in the direction of the arrow. "HOLD" will flash three times, indicating that all the functions of the buttons are locked.



**To cancel the HOLD function**  
Slide the HOLD switch in the opposite direction of the arrow.

**Note**  
When the HOLD function is activated during recording, cancel the HOLD function first to stop recording.

**Tip**  
Even if the HOLD function is activated, you can stop the alarm playback. To stop the alarm or playback, press **STOP**.

### Selecting the Display Mode

You can select the display mode for the stop, recording and playback modes. Each time you press **DISPLAY**, the display mode will change as shown below:

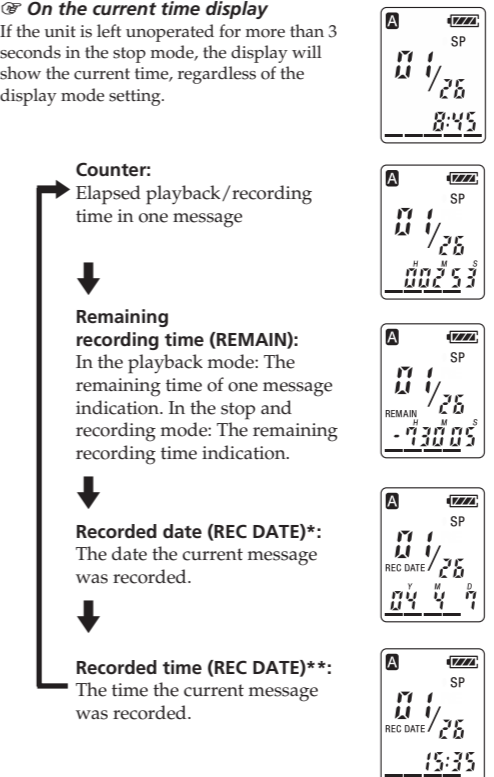

\* If the clock has not been set, "-Y-M-D" will be displayed.  
\*\* If the clock has not been set, "-:-" will be displayed.

## Turning off the Beep Sound

**BEEP ON:** A beep will sound to indicate that operation has been accepted.

**BEEP OFF:** No beep sound will be heard except for the alarm and timer.

- Press **MENU** to enter the menu mode.
- Press **←** or **→** to display "BEEP ON (or OFF)" and press **PLAY/STOP**. "ON (or OFF)" will flash.
- Press **←** or **→** to select "ON" or "OFF" and press **PLAY/STOP**. The setting is completed.
- Press **MENU** to exit the menu mode.

**To cancel the alarm setting or change the alarm time**

- Select the message you set the alarm to play back, and press **MENU**. "ALARM ON" will be displayed.
- Press **PLAY/STOP** to flash "ON".
- To cancel the alarm setting: Press **←** or **→** to flash "OFF" and press **PLAY/STOP**. To change the alarm date and time: Press **PLAY/STOP**. When the alarm date is displayed, follow the steps 3 to 5 above to change the alarm date and time.
- Press **MENU** to exit the menu mode.

## Changing the Recording Mode

**HQ:** You can record with the high quality sound (monaural sound).

**SP:** You can record with better sound (monaural sound).

**LP:** You can record for longer time (monaural sound).

- Press **MENU** to enter the menu mode.
- Make sure that "MODE" is displayed and press **PLAY/STOP**. "SP (or HQ, LP)" will flash.
- Press **←** or **→** to select "HQ", "SP" or "LP" and press **PLAY/STOP**. Now the setting is completed.
- Press **MENU** to exit the menu mode. The setting becomes effective and the normal screen will be displayed.

If the unit is left unoperated for more than 3 seconds in the stop mode, the display will show the current time and the selected recording mode will be displayed.

## Playing Back All Messages in a Folder Continuously

**CONT ON:** You can play back all messages in a folder continuously.

**CONT OFF:** Playback stops at the end of each message.

- Press **MENU** to enter the menu mode.
- Press **←** or **→** to display "CONT" and press **PLAY/STOP**. "OFF (or ON)" will flash.
- Press **←** or **→** to select "ON" or "OFF" and press **PLAY/STOP**. Now the setting is completed.
- Press **MENU** to exit the menu mode.

## Specifications

Recording media  
Built-in flash memory 16MB (ICD-B100)/32MB (ICD-B200), Monaural recording

Recording time  
ICD-B100:  
HQ: 1 hour 45 minutes  
SP: 4 hours 50 minutes  
LP: 8 hours  
ICD-B200:  
HQ: 3 hours 40 minutes  
SP: 9 hours 50 minutes  
LP: 16 hours 10 minutes

Frequency range  
HQ: 250 Hz - 6,800 Hz  
SP/LP: 220 Hz - 3,400 Hz

Speaker approx. 2.0 cm (13/16 in.) dia.

Power output 250 mW

Input/Output  
• Earphone jack (mini) for 8 - 300 ohms ear receiver/headphones  
• Microphone jack (mini) (monaural)  
Plug in power  
Minimum input level 0.6 mV  
3 kilohms or lower impedance microphone

Power requirements Two LR03 (size AAA) alkaline batteries: 3 V DC

Dimensions (w/h/d) (not incl. projecting parts and controls)  
30.0 × 103.5 × 16.0 mm (1 3/16 × 4 1/8 × 21/32 in.)

Mass (incl. batteries) 58 g (2.1 oz)

Supplied accessories  
Operating instructions (1)  
LR03 (size AAA) alkaline batteries (2) (For the U.S.A. and U.K. only)

Optional accessories  
Electret Condenser Microphone ECM-C10, ECM-DM5P, ECM-Z60, ECM-TL1 (for telephone recording)  
Audio connecting cable RK-G64HG / RK-G69HG (excluding Europe)  
Active speaker SRS-T88, SRS-T80

Your dealer may not handle some of the above listed optional accessories. Please ask the dealer for detailed information.

Design and specifications are subject to change without notice.